

Features:

- n Non-Isolated. Mounting base as anode or cathode terminal
- n Pressure contact technology with Increased power cycling capability
- n Low on-state voltage drop

Typical Applications

- n Welding Power Supply
- n Various DC Power supplies
- n DC supply for PWM inverter

V _{RRM} , V _{DRM}	Type & Outline	
800V	MTx100-08-213F4	MFx100-08-213F4
1000V	MTx100-10-213F4	MFx100-10-213F4
1200V	MTx100-12-213F4	MFx100-12-213F4
1400V	MTx100-14-213F4	MFx100-14-213F4
1600V	MTx100-16-213F4	MFx100-16-213F4
1800V	MTx100-18-213F4	MFx100-18-213F4

MTx stands for any type of **MTG, MTY**
 MFx stands for any type of **MFG, MFY**

SYMBOL	CHARACTERISTIC	TEST CONDITIONS	T _j (°C)	VALUE			UNIT
				Min	Type	Max	
I _{T(AV)}	Mean on-state current	180° half sine wave 50Hz Single side cooled, T _c =90°C	125			100	A
I _{T(RMS)}	RMS on-state current					157	A
I _{DRM} I _{RRM}	Repetitive peak current	at V _{DRM} at V _{RRM}	125			12	mA
I _{TSM}	Surge on-state current	V _R =60%V _{RRM} , t=10ms half sine	125			2.5	kA
I ² t	I ² t for fusing coordination		125			31	10 ³ A ² s
V _{TO}	Threshold voltage		125			0.80	V
r _T	On-state slope resistance					2.45	mΩ
V _{TM}	Peak on-state voltage	I _{TM} =300A	25			1.67	V
dv/dt	Critical rate of rise of off-state voltage	V _{DM} =67%V _{DRM}	125			800	V/μs
di/dt	Critical rate of rise of on-state current	Gate source 1.5A t _r ≤0.5μs Repetitive	125			100	A/μs
I _{GT}	Gate trigger current	V _A =12V, I _A =1A	25	30		100	mA
V _{GT}	Gate trigger voltage			0.8		2.5	V
I _H	Holding current			10		180	mA
V _{GD}	Non-trigger gate voltage	V _{DM} =67%V _{DRM}	125			0.20	V
R _{th(j-c)}	Thermal resistance Junction to case	At 180° sine, Single side cooled				0.25	°C/W
R _{th(c-h)}	Thermal resistance case to heatsink	At 180° sine, Single side cooled				0.10	°C/W
F _m	Terminal connection torque(M6)			4.5		6.0	N·m
	Mounting torque(M6)			4.5		6.0	N·m
T _{vj}	Junction temperature			-40		125	°C
T _{stg}	Stored temperature			-40		125	°C
W _t	Weight					280	g
Outline	213F4						

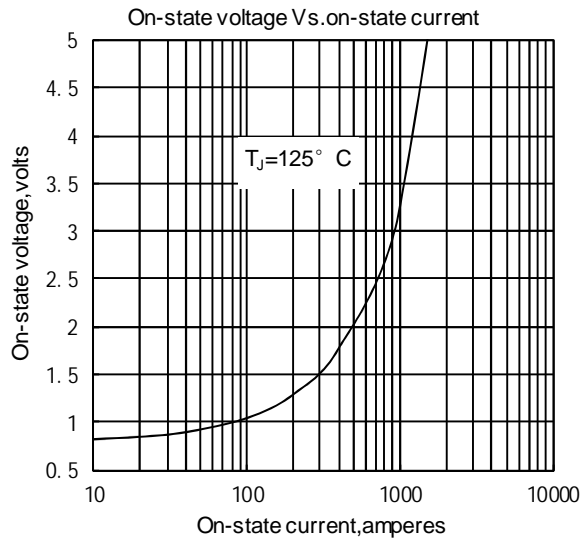

Fig.1

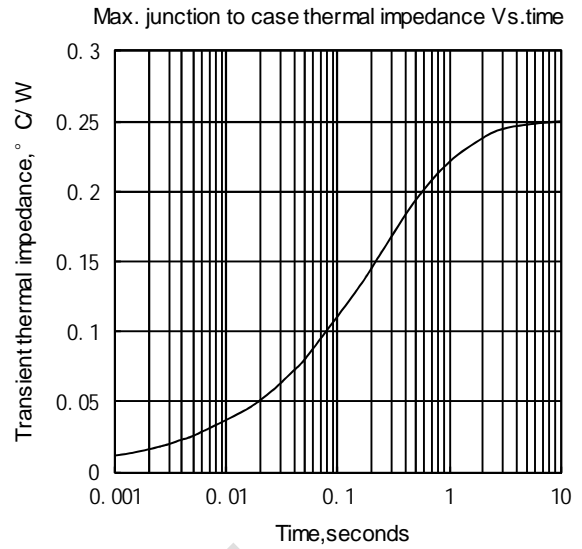

Fig.2

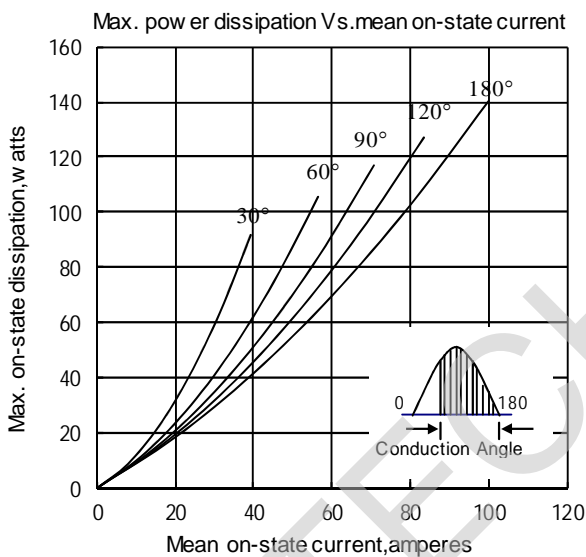

Fig.3

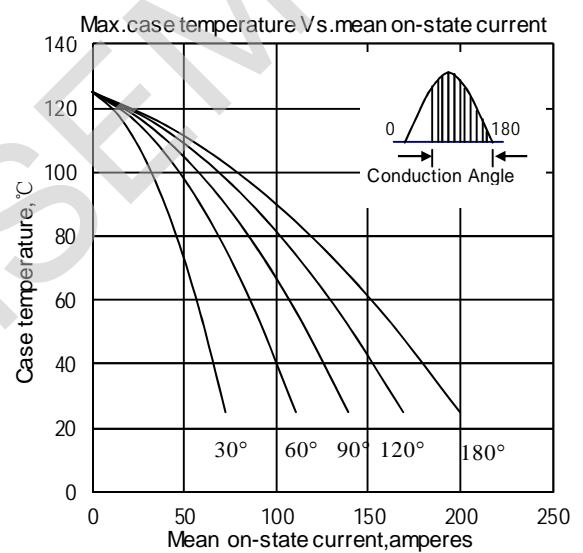

Fig.4

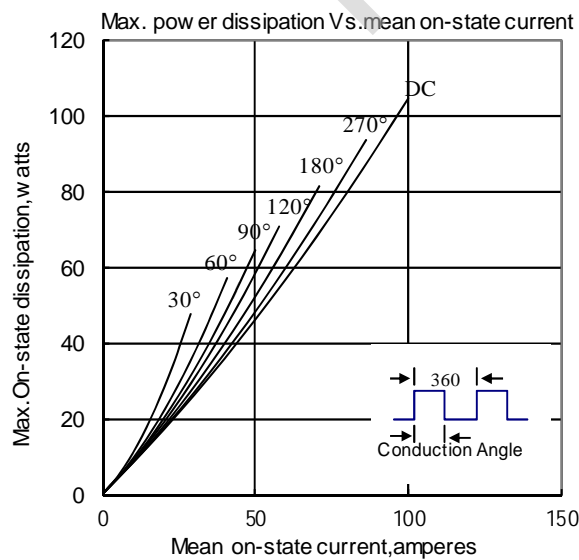

Fig.5

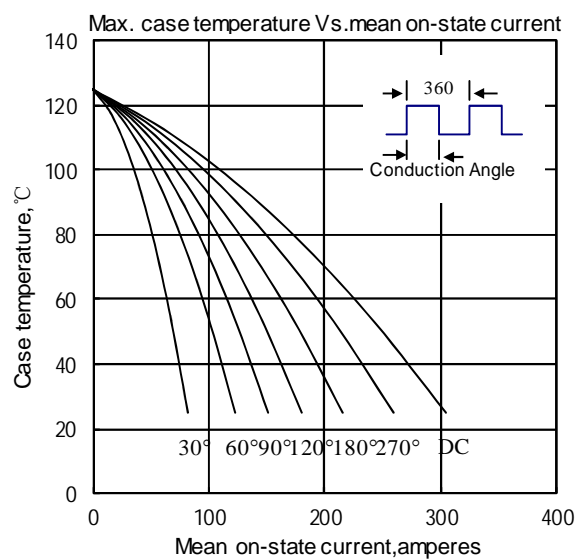

Fig.6

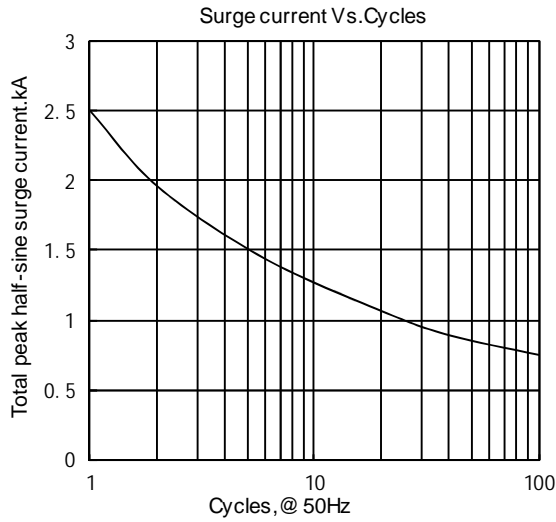

Fig.7

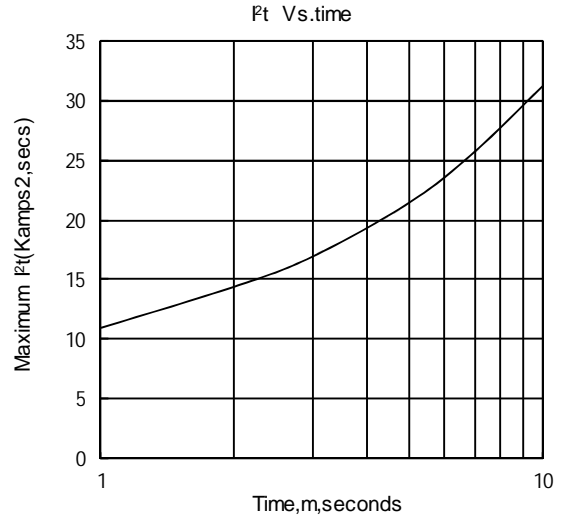

Fig.8

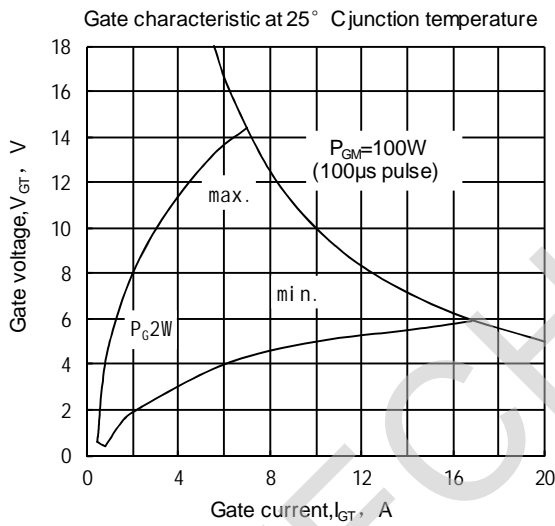

Fig.9

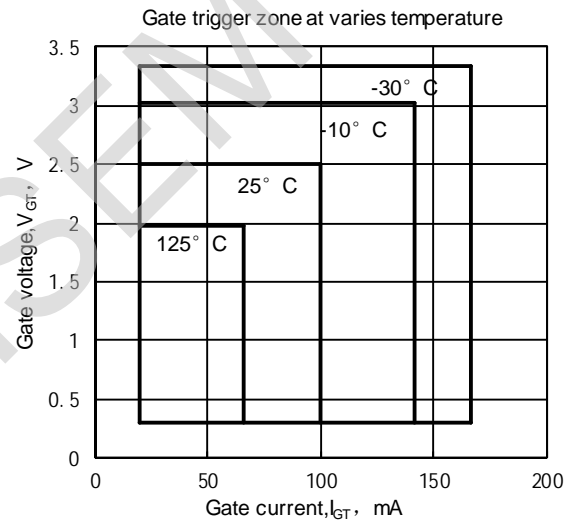
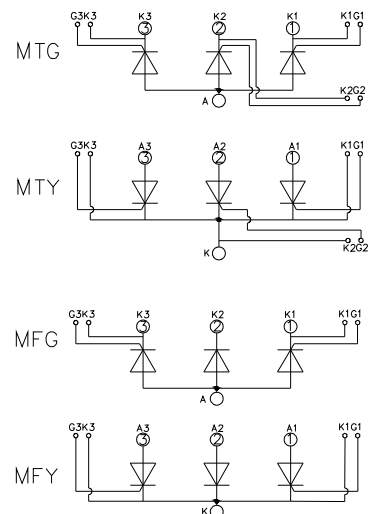
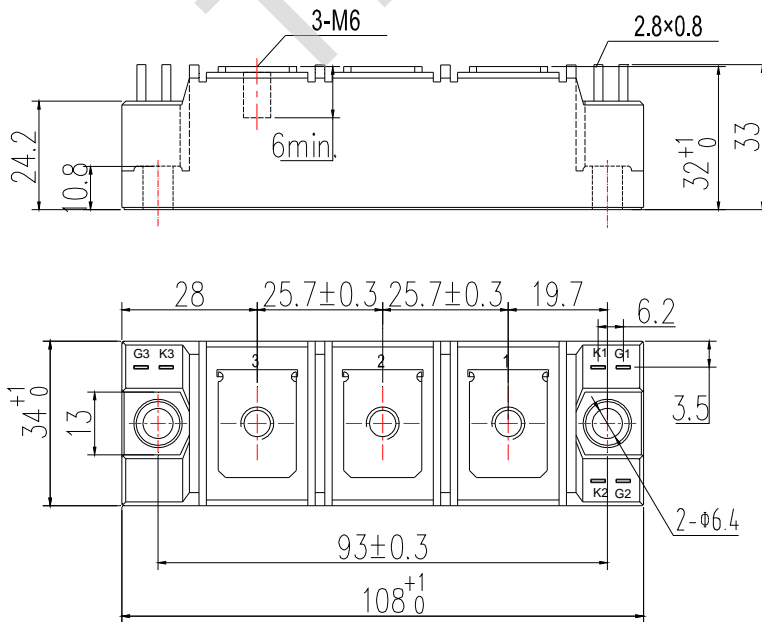

Fig.10

Outline:



Unmarked dimensional tolerance: ±0.5mm