**Features:**

- n Isolated mounting base 3000V~
- n Pressure contact technology with Increased power cycling capability
- n Space and weight saving

Typical Applications

- n Various rectifiers
- n DC supply for PWM inverter

| V_{RRM} | Type & Outline |
|-----------|----------------|
| 800V | MD500-08-417F2 |
| 1000V | MD500-10-417F2 |
| 1300V | MD500-12-417F2 |
| 1500V | MD500-14-417F2 |
| 1600V | MD500-16-417F2 |
| 1800V | MD500-18-417F2 |

| SYMBOL | CHARACTERISTIC | TEST CONDITIONS | $T_j(^{\circ}C)$ | VALUE | | | UNIT |
|---------------|--|--|------------------|-------|------|-------|---------------|
| | | | | Min | Type | Max | |
| $I_{F(AV)}$ | Mean forward current | 180° half sine wave 50Hz Single side cooled, $T_c=100^{\circ}C$ | 150 | | | 500 | A |
| $I_{F(RMS)}$ | RMS forward current | | | | | 785 | A |
| I_{RRM} | Repetitive peak current | at V_{RRM} | 150 | | | 40 | mA |
| I_{FSM} | Surge forward current | $V_R=60\%V_{RRM}$, $t=10ms$ half sine | 150 | | | 16.0 | kA |
| I^2t | I^2t for fusing coordination | | | | | 1280 | 10^3A^2s |
| V_{FO} | Threshold voltage | | 150 | | | 0.75 | V |
| r_F | Forward slope resistance | | | | | 0.30 | m Ω |
| V_{FM} | Peak forward voltage | $I_{FM}=1500A$ | 25 | | | 1.32 | V |
| $R_{th(j-c)}$ | Thermal resistance Junction to case | Single side cooled per chip | | | | 0.090 | $^{\circ}C/W$ |
| $R_{th(c-h)}$ | Thermal resistance case to heatsink | Single side cooled per chip | | | | 0.024 | $^{\circ}C/W$ |
| V_{iso} | Isolation voltage | 50Hz, R.M.S, $t=1min$, $I_{iso}:1mA(MAX)$ | | 3000 | | | V |
| F_m | Terminal connection torque(M10) | | | 10 | | 12 | N·m |
| | Mounting torque(M6) | | | 4.5 | | 6.0 | N·m |
| T_{vj} | Junction temperature | | | -40 | | 150 | $^{\circ}C$ |
| T_{stg} | Stored temperature | | | -40 | | 125 | $^{\circ}C$ |
| W_t | Weight | | | | 770 | | g |
| Outline | 417F2 | | | | | | |

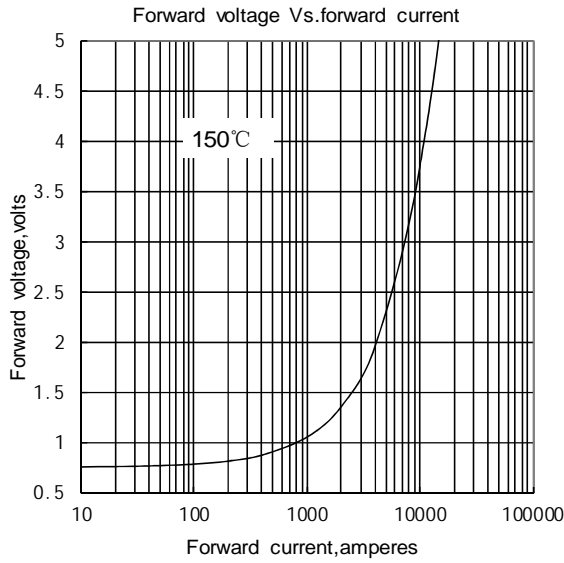

Fig.1

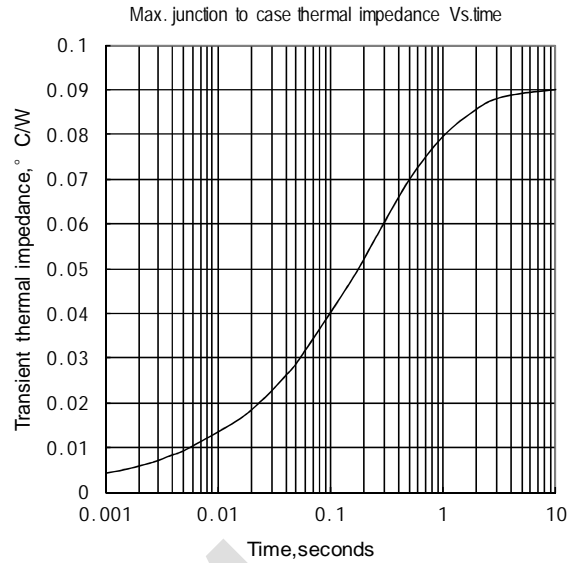

Fig.2

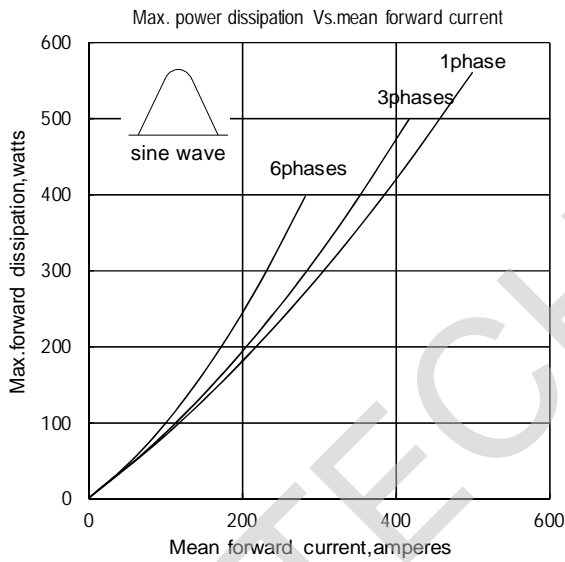

Fig.3

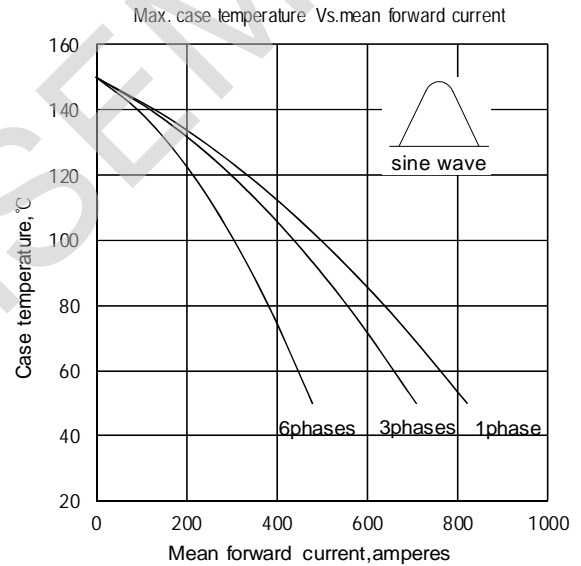

Fig.4

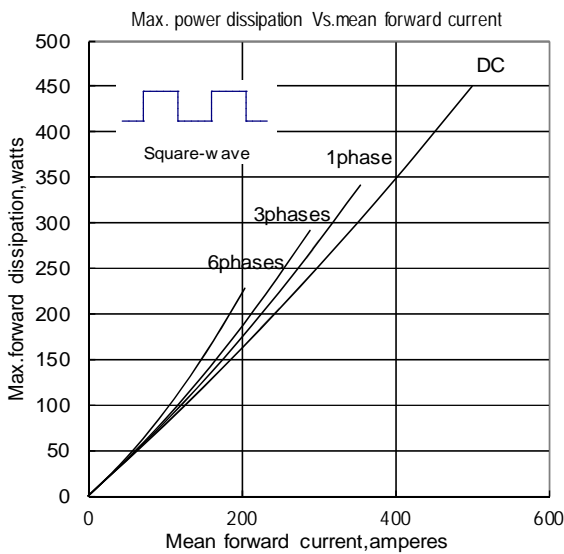

Fig.5

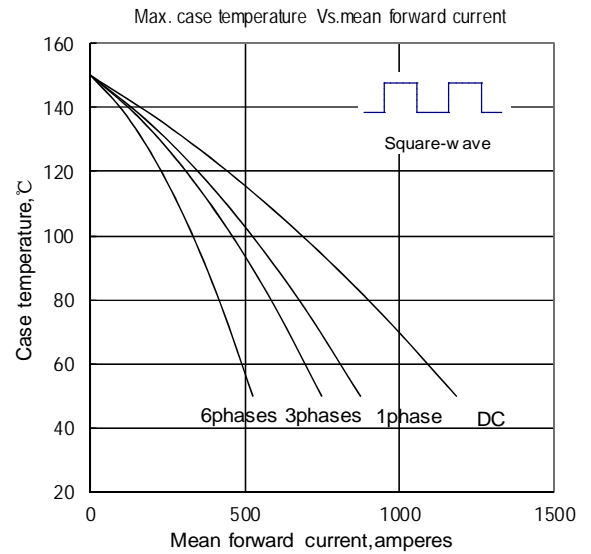

Fig.6

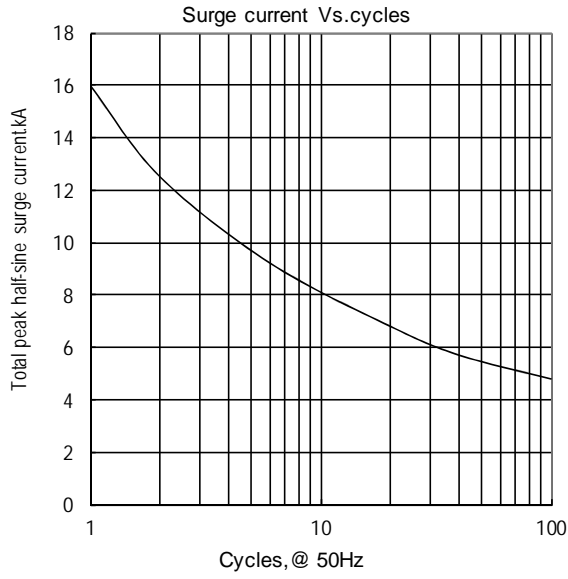

Fig.7

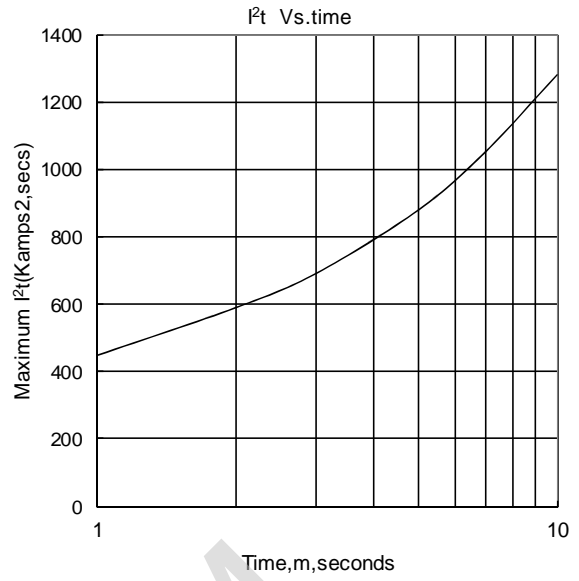
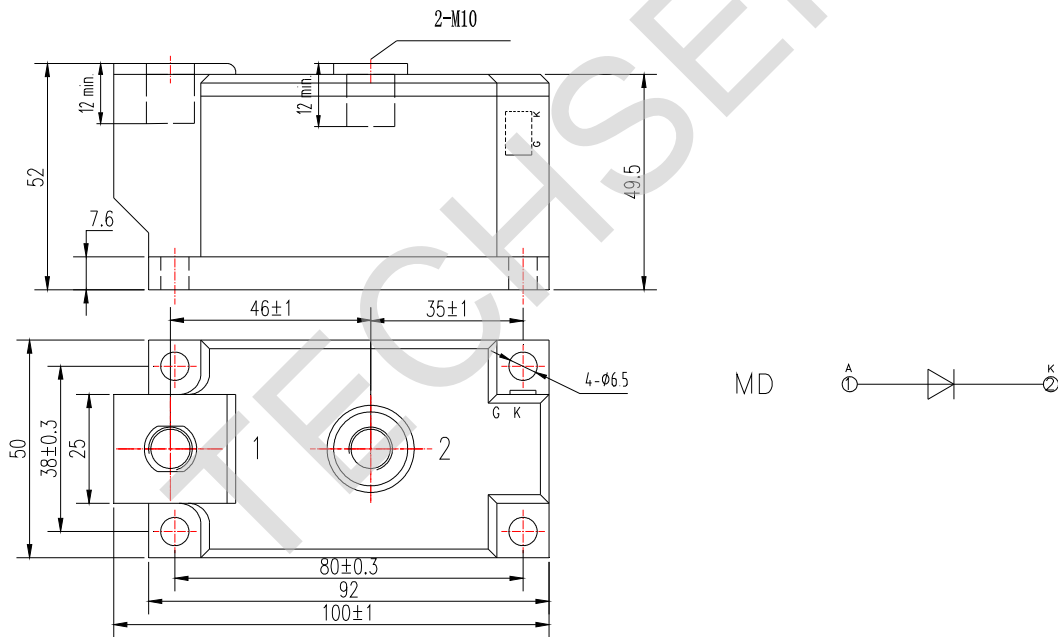

Fig.8

Outline:



Unmarked dimensional tolerance: ±0.5mm