

**Features :**

- Isolated mounting base 4000V~
- Pressure contact technology with Increased power cycling capability
- Space and weight saving

**Typical Applications**

- AC/DC Motor drives
- Various rectifiers
- DC supply for PWM inverter

V <sub>DSM</sub> , V <sub>RSM</sub>	V <sub>DRM</sub> , V <sub>RRM</sub>	Type & Outline
2700V	2600V	MFx250-26-415F3
2900V	2800V	MFx250-28-415F3
3100V	3000V	MFx250-30-415F3
3300V	3200V	MFx250-32-415F3
3500V	3400V	MFx250-34-415F3
3700V	3600V	MFx250-36-415F3

SYMBOL	CHARACTERISTIC	TEST CONDITIONS	T <sub>j</sub> (°C)	VALUE			UNIT
				Min	Type	Max	
I <sub>T(AV)</sub>	Mean on-state current	180° half sine wave 50Hz Single side cooled, T <sub>c</sub> =85°C	125			250	A
I <sub>T(RMS)</sub>	RMS on-state current					393	A
I <sub>DRM</sub> I <sub>RRM</sub>	Repetitive peak current	at V <sub>DRM</sub> at V <sub>RRM</sub>	125			40	mA
I <sub>TSM</sub>	Surge on-state current	10ms half sine wave	125			7	kA
I <sup>2</sup> t	I <sup>2</sup> t for fusing coordination	V <sub>R</sub> =60%V <sub>RRM</sub>				245	A <sup>2</sup> s*10 <sup>3</sup>
V <sub>TO</sub>	Threshold voltage		125			0.91	V
r <sub>T</sub>	On-state slope resistance					0.90	mΩ
V <sub>TM</sub>	Peak on-state voltage	I <sub>TM</sub> =750A	25			2.63	V
dv/dt	Critical rate of rise of off-state voltage	V <sub>DM</sub> =67%V <sub>DRM</sub>	125			800	V/μs
di/dt	Critical rate of rise of on-state current	Gate source 1.5A t <sub>r</sub> ≤ 0.5μs Repetitive	125			100	A/μs
I <sub>GT</sub>	Gate trigger current	V <sub>A</sub> =12V, I <sub>A</sub> =1A	25	30		180	mA
V <sub>GT</sub>	Gate trigger voltage			0.8		2.5	V
I <sub>H</sub>	Holding current			10		200	mA
V <sub>GD</sub>	Non-trigger gate voltage	V <sub>DM</sub> =67%V <sub>DRM</sub>	125	0.2			V
R <sub>th(j-c)</sub>	Thermal resistance Junction to case	Single side cooled per chip				0.11	°C /W
R <sub>th(c-h)</sub>	Thermal resistance case to heat sink	Single side cooled per chip				0.04	°C /W
V <sub>iso</sub>	Isolation voltage	50Hz, R.M.S, t=1min, I <sub>iso</sub> : 1mA(MAX)		4000			V
F <sub>m</sub>	Terminal connection torque (M10)				12.0		N·m
	Mounting torque (M6)				6.0		N·m
T <sub>vj</sub>	Junction temperature			-40		125	°C
T <sub>stg</sub>	Stored temperature			-40		125	°C
W <sub>t</sub>	Weight				1275		g
Outline	415F3						

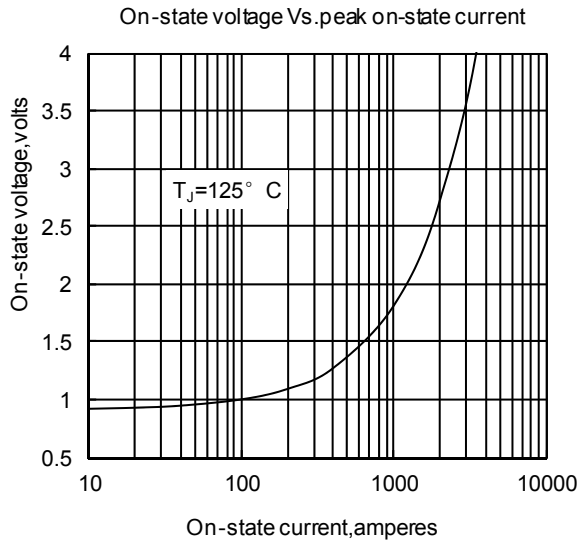

Fig. 1

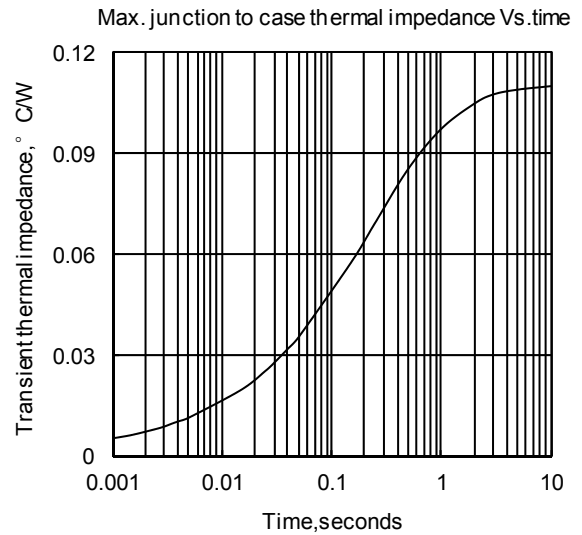

Fig. 2

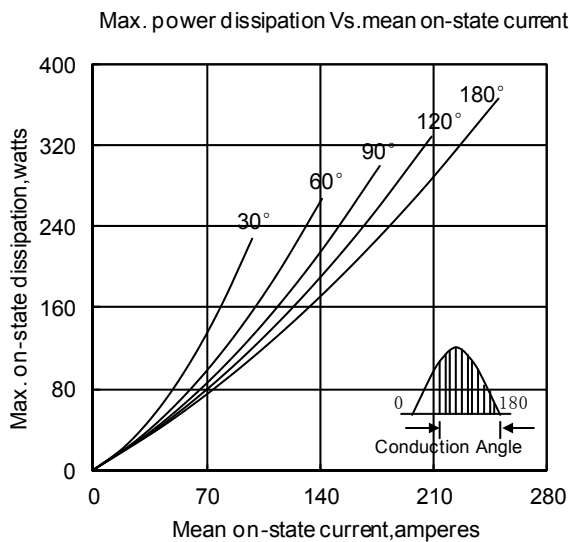

Fig. 3

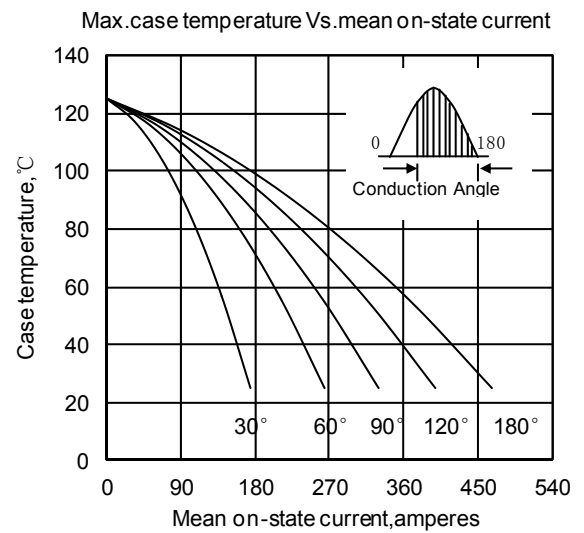

Fig. 4

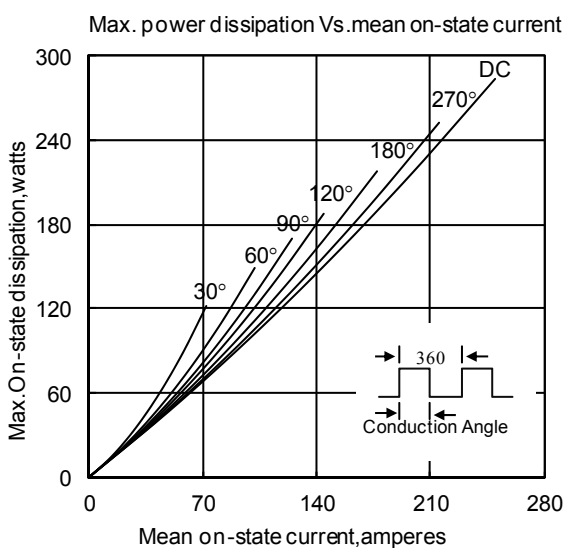

Fig. 5

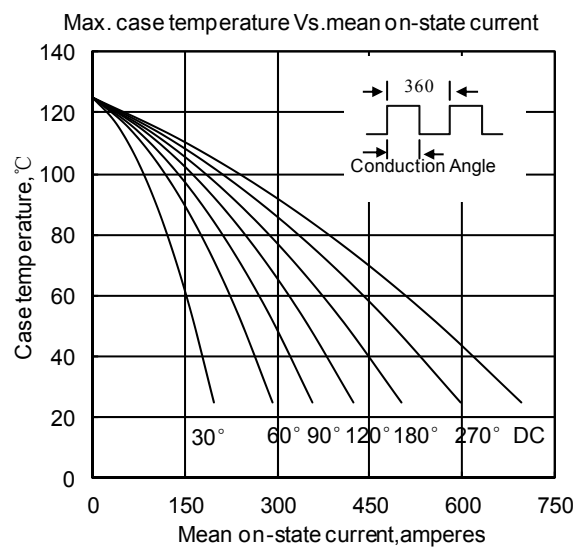

Fig. 6

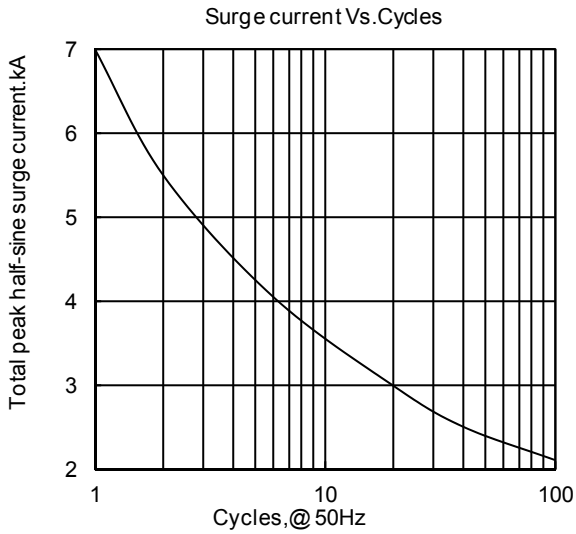

Fig. 7

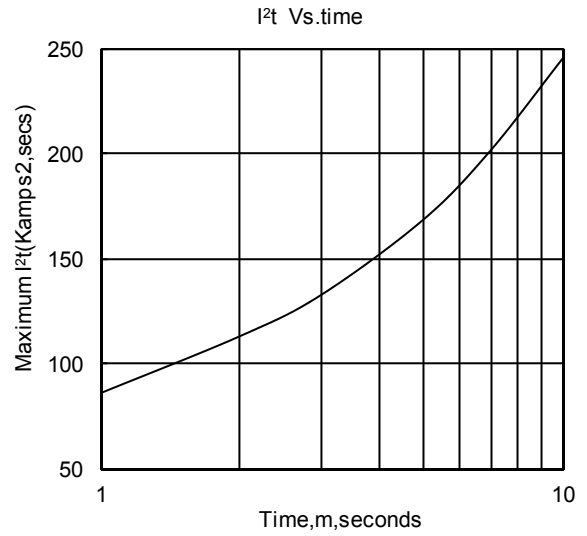

Fig. 8

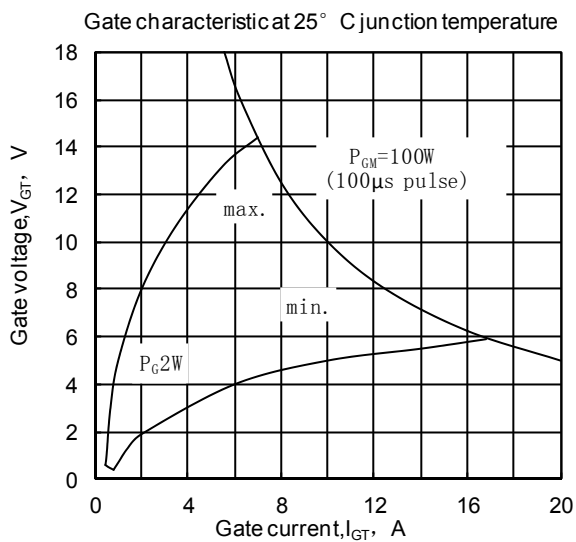

Fig. 9

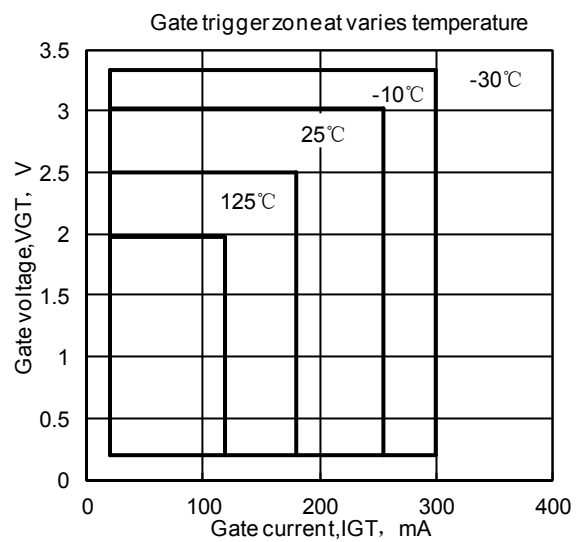
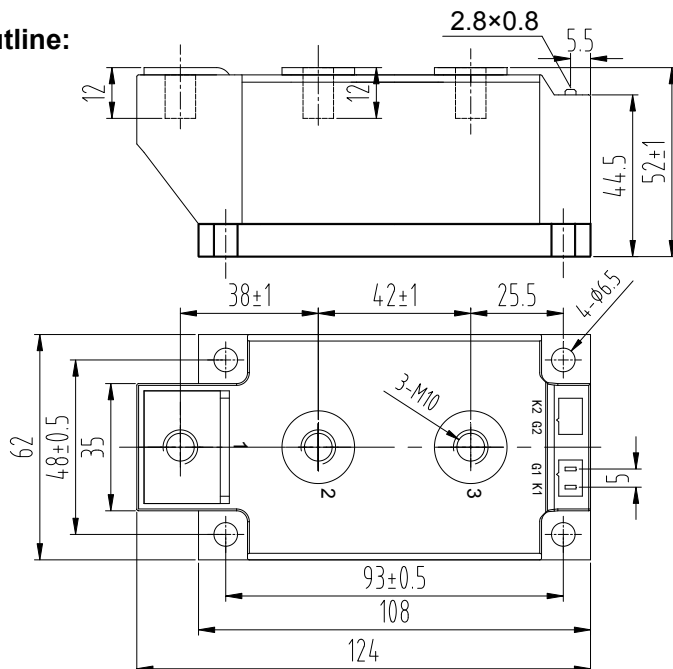
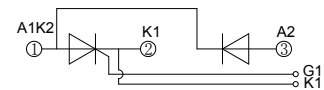

Fig. 10

Outline:



MFC (TD)



MFA (TD)

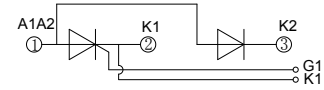

MFK (TD)

